

Cable Railing Installation Instructions

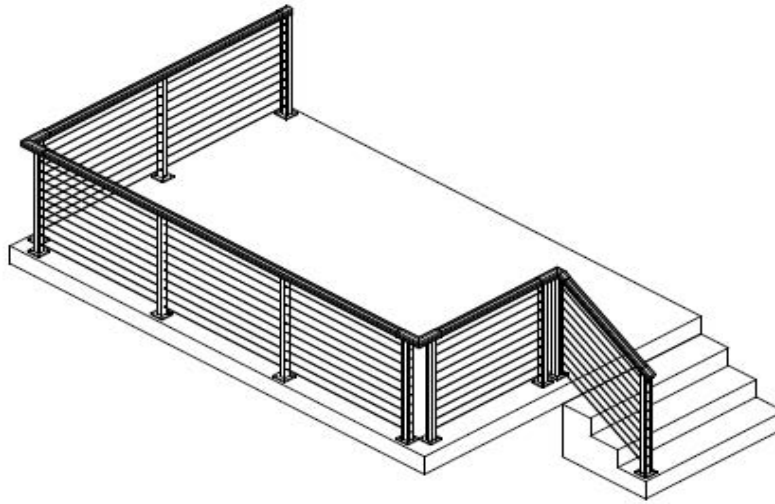

TOOLS & MATERIALS REQUIRED

- 10" Miter (w/ Carbide Triple Chip Blade) or Hacksaw
- Tape Measure
- Electric power cords
- Pencil
- 1/8", 5/32", 3/16", and 1/4" Drill Bits
- Cordless or Electric Drill, variable speed
- Level
- Socket Set (if using Lag Bolts or Wedge Anchors)
- Hammer Drill for concrete or stucco applications
- Exact-o-knife
- Vice Grips
- Allen Key
- Urethane Caulking and Caulking Gun
- Robertson #2 Bit Head / #3 Bit Head
- Straight Screw Driver (Chicago Bolts)
- Hex Head Driver Bits (#10 Tek & #14 Tek)
- **NOTE: DO NOT USE AN IMPACT DRILL**

WARNING

No representation or warranty is given that your particular application of these products complies with relevant building codes or that the fasteners provided or used are appropriate for your application. Therefore consult with professionals and local building officials before beginning work; (i) to ensure compliance with relevant building codes for your application and for your proposed use of fasteners; (ii) to ensure the integrity of the structural components in connection with which these products are to be used (iii) to identify appropriate safety gear that is to be used during installation such as safety harness when working above ground; (iv) to ensure that the work area is free from utilities, services and hazards; and (v) to clarify any instructions or warning that may not be clear. Always work in a safe manner wearing protective gear such as gloves, eyewear, headwear, footwear and clothing. When using tools always comply with operating manuals and instructions. Metal and glass may have sharp edges and could fragment or splinter during or as a result of handling or cutting. Do not use these products in connection with any substance that is or may be harmful or corrosive to the products. Inspect and maintain these products and the structural components that they are used in connection with on a regular basis using professionals when appropriate. These instructions have been prepared for certain standard residential applications. Obtain professional advice for any non-standard or non-residential application.

.....

No member of Excell Railing Systems shall be liable for any loss or damage resulting from improper installation or use of this product. In the unlikely event that any member of Excell Railing Systems becomes liable for any loss or damage, the aggregate liability shall be limited to the retail purchase price of the product.

Cable Railing Installation Instructions

STEP 1: POST PLACEMENT and SETUP

- a) Based on your deck layout, place posts on the deck equally spaced apart, ensuring each mounting area has adequate solid blocking.

For layouts with stairs, place your stair posts first (see Cable Stairs - Generic Layout drawing for placement dimensions).

Cable Systems require double posting at angle changes and for every 50 feet of straight run.

- b) Once you have the posts placed into their positions, (approx. 1-2" from edge of the post base plate-to-edge of deck), pre-drill one hole and then fasten the post to the deck with 1 fastener, making sure to leave 1/2" of screw above the post base plate.

NOTE: It is recommended that you use the double post mount top sleeves, by placing them inside of both posts, for helping to ensure corner posts are placed with the correct spacing. Also, see "**Double Post Placement**" sheet for additional help.

- c) Starting at one end of the deck, plumb the end post. Plastic E-Z Shims can be used under the base plates for these adjustments.

Once you are satisfied with the adjustments, pre-drill the remaining 3 holes in the deck and then fill them with Urethane Caulking.

Insert the shoulder washers into the base plate holes.

Put a little Urethane Caulking onto the threads of the screws and snug the screws down; making sure you do not over tighten (don't forget to back out the original fastener and apply the Urethane Caulking into the hole and on the screw and then insert the shoulder washer before re-inserting this fastener).

As railing becomes secure, once again, double check posts are plum and square. Some re-adjusting may be required.

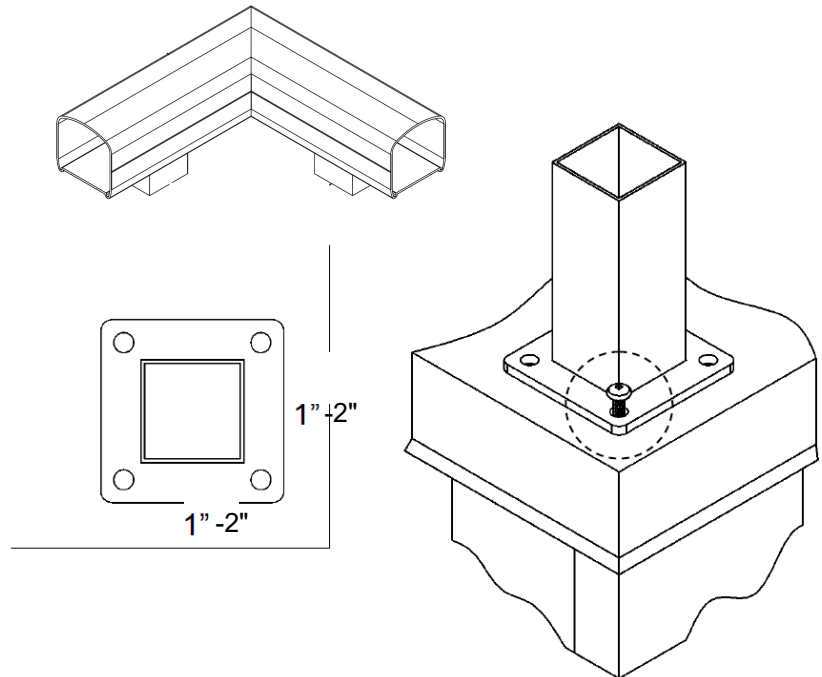
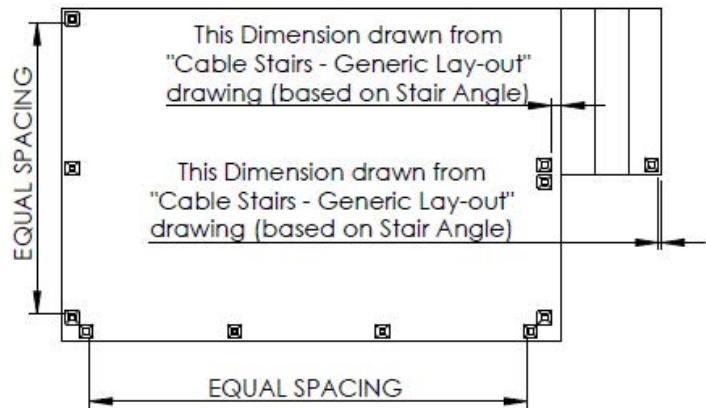

Cable Railing Installation Instructions

STEP 2: INSTALLING TOP RAIL AND SLEEVES

- a) Place the top sleeves in each of the appropriate posts and pre-drill a hole, using a 1/8" drill bit, through the post and into the top sleeve post mount. Typically done on the side facing off the deck.
- b) If you are installing using Post Mount Plates, fasten each plate to the appropriate post using (2) #10 x 3/4" Tek screws - centering the plate on the post. If you are not using Post Mount Plates then skip this step.
- c) Measure from the inside of your post with a top sleeve to the inside of the next post with a top sleeve. Measure this length out on your top rail and cut it to length. Repeat this for each piece of required top rail.
- d) Join the top rails together by sliding the rails into the post sleeves; so that it is approximately flush with the edge of the post.
- e) Secure the top sleeve to the post using a #10 x 3/4" Tek screw through the pre-drilled hole; then secure the top rail to the top sleeve using a #10 x 3/4" Tek screw, from the underside of the top rail.
- f) Attach the Post Mount Plates to the top rail using (2) #10 x 3/4" Tek screws. If you are not using Post Mount Plates then skip this step.

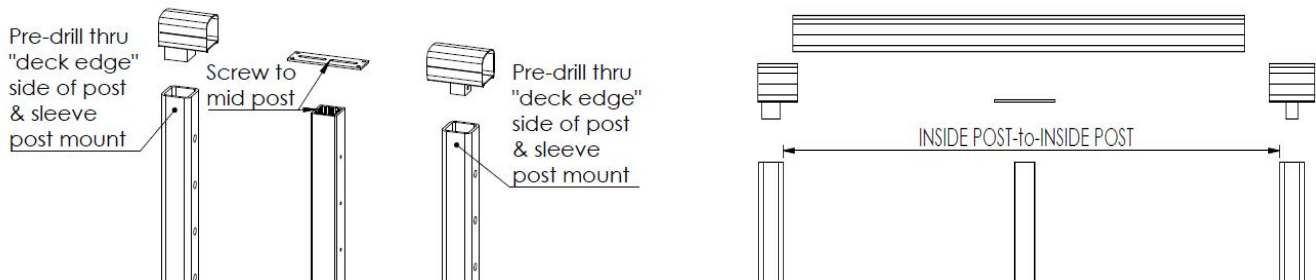

STEP 3: INSTALLING CABLE SYSTEM INTO POSTS

- a) You are now ready to install the cable itself. Please follow the instructions on the "Cable Installation" sheet.

NOTE: Now that installation is complete, clean the railing of fingerprints using Vim or car polish.

DURARAIL.COM

STEP 1

Slip the washer over the body of the Receiver.
Feed the Receiver through back of the post.
By hand, screw the Receiver onto the swaged stud at least 2 full turns.
Do not tension cables until all cables have been installed between end posts A and B.
Repeat this for each cable to be installed between end posts A and B.

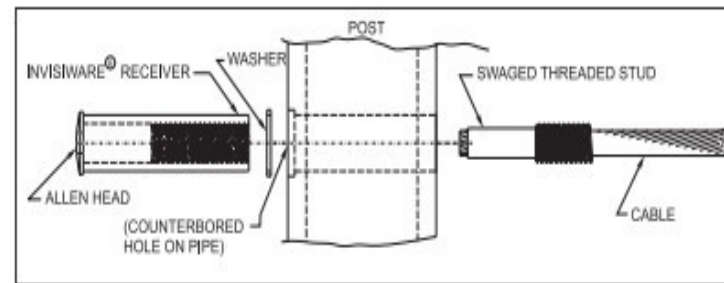

STEP 2

Run the cable through the intermediate posts (if any) and through Post B where you will be installing the PullLock® fittings.

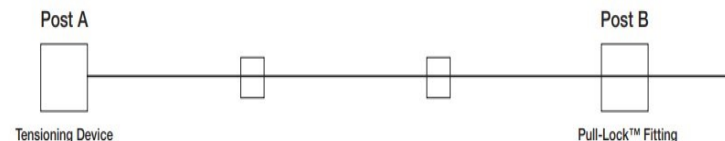

STEP 3

Slip the washer over the body of the Pull-Lock® fitting

STEP 4

Push the cable into the hole in the front of the PullLock® fitting and pull the cable through the fitting, while twisting the cable clockwise.
Slide the fitting along the cable and up to the back side of the post.

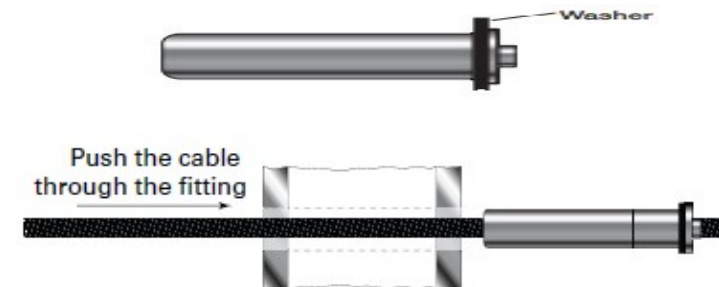

STEP 5

Hold the cable with one hand and slide the Pull-Lock® fitting into the hole in the post.
Press on the back of the Pull-Lock® fitting to hold it securely in the post and pull the cable through the fitting until it is as tight as you can make it.



STEP 6

Cut the cable flush with the hole in the back of the fitting using a cut-off wheel (or some other appropriate cutting tool).



STEP 7

Press the cap onto the lip of the Pull-Lock fitting.

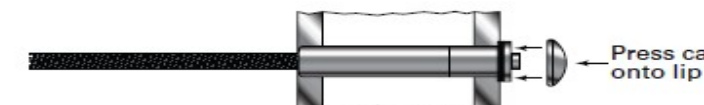

STEP 8

Go to the other end and tension the cable by holding the cable securely to prevent it from turning while you turn the Receiver with an Allen hex wrench. (Be careful to protect the cable from damage while tensioning.)



Drawing Name:

Cable Installation

Customer:

Excell Railing System

Project Name:

- Cable Railing -
Installation Instructions
for Cables

Dwn By: RDM

Chk'd By: --

Date Created:

May 10, 2024

Scale:

Not To Scale

TENSIONING INSTRUCTIONS:

Tension in sequence, starting with the Centermost cable and moving up and down toward the top and bottom.
Note: Finished cables should be tensioned to have only 1/4" of play when finger-pulled.

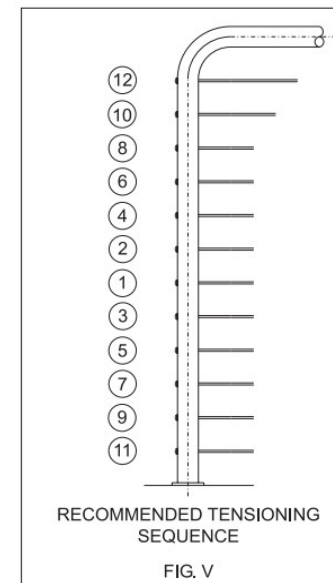

ALL DIMENSIONS ARE SUBJECT TO SITE MEASUREMENTS AND ARE TO BE CONFIRMED BEFORE FABRICATION OF PRODUCT

- - Per E-Mail received (date)

No. BY

Revision

Optional Way to Place Posts for Double Post Mount

Place two loose base plates as shown in white next to the cable posts, to form a perfect square. Place your 90° sleeve with the double post mounts to confirm positioning. Once you have figured out where you want your corner posts, screw them down as described on page 2 and plumb them up.

NOTE: If you do not have 2 loose base plates use 2 extra posts.

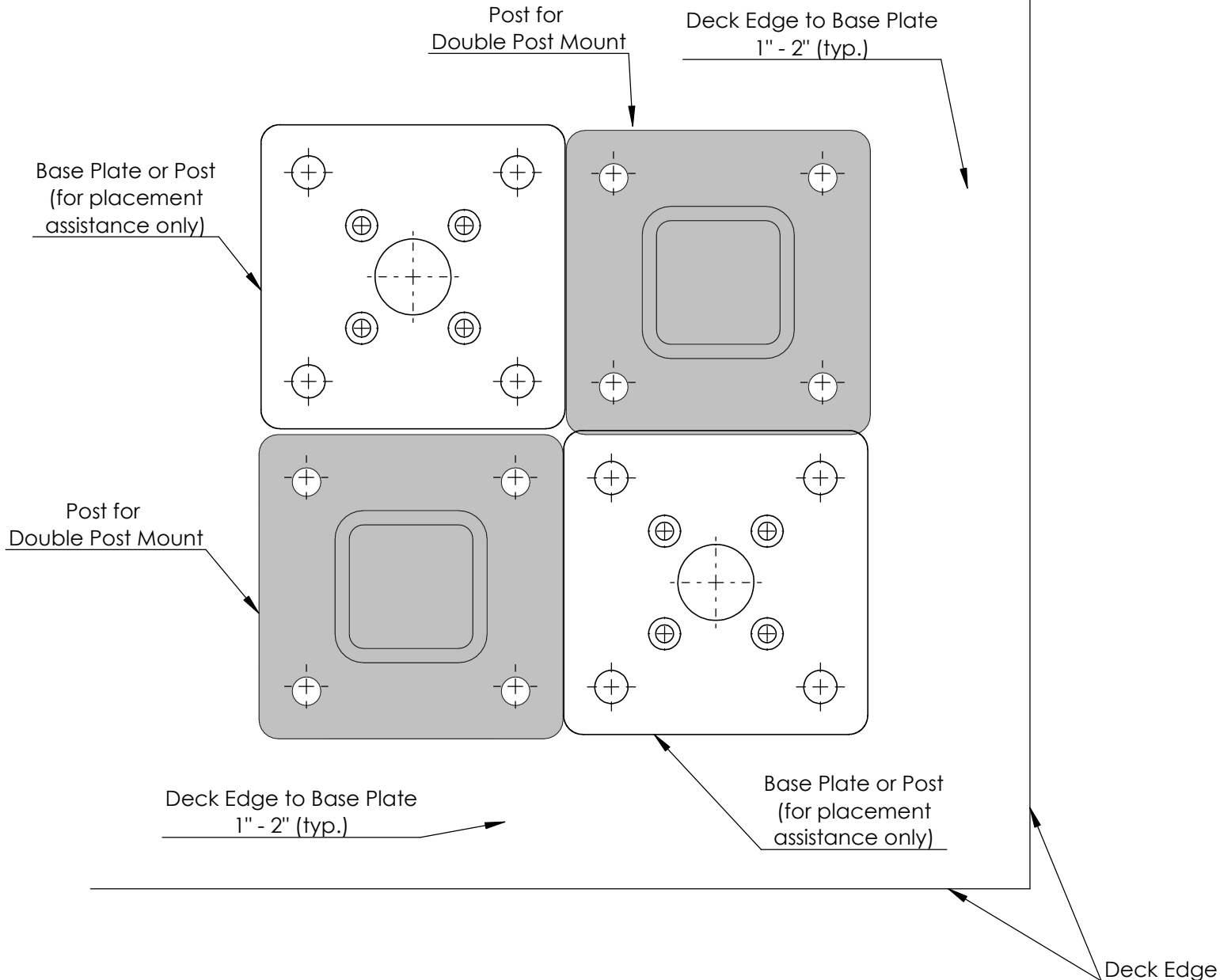









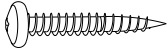

EXCELL

RAILING SYSTEMS LTD
 #306 - 12886 Anvil Way Surrey, BC V3W 8E7
 Phone: 604-501-0151 Fax: 604-501-0155
 Toll Free: 1-866-999-7245 www.excellrailing.com

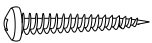
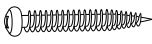
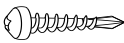
Drawing Name: Double Post Placement	
Customer: Excell Railing System	
Project Name: Cable Rail Installation Instructions	
Dwn By: RDM	Chk'd By: --
Date Created: July 3, 2024	
Scale: Not To Scale	
GENERAL NOTES:	
MATERIALS:	
- Aluminum alloy and temper:	
Posts	6005A-T61
Rails	6063-T5
Baseplate	6005A-T61
- Design Specifications and Standards for Aluminum Structures Aluminum Association	
- Screws for railing system assembly as per manufacturer's specification	
POWDER COATING SPECIFICATION:	
- Finished powder coat color is TBD	
- Powder coat meet AAMA-2604-02 Voluntary Specifications.	
Performance Requirements and Test Procedures for Pigmented Organic Coatings on Aluminum Extrusions and Pickets.	
OTHERS:	
- Rail assembly to meet all specification requirements as stated in attached	
- Contractor to field verify all dimensions and quantities prior to fabrication	
ENGINEERING STAMP & DATE	
-	- Per E-Mail received (date)
No.	BY Revision

ALL DIMENSIONS ARE SUBJECT TO SITE MEASUREMENTS AND ARE TO BE CONFIRMED BEFORE FABRICATION OF PRODUCT

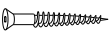
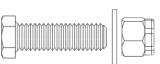

Fasteners	Usage, Notes, & Mill Finish Part Number
#14x3" Pan Head Stainless Steel Screw 	<ul style="list-style-type: none"> Fasten post to wood deck (not engineered) Can be ordered painted or mill finish <p style="text-align: right;">MFSCSSP143</p>
#14x2" Pan Head Stainless Steel Screw 	<ul style="list-style-type: none"> Fasten post to wood deck (not engineered) Can be ordered painted or mill finish <p style="text-align: right;">MFSCSSP142</p>
1/4"-20x2" Flat Head Phillips Drive Cutting Screw 	<ul style="list-style-type: none"> Fasten post base plate to 1.72" post material Mill finish only <p style="text-align: right;">MFSCFH252</p>
#12x3" Pan Head Stainless Steel Screw 	<ul style="list-style-type: none"> Fasten 1.6" inside wall mount to wall Mill finish only <p style="text-align: right;">MFSCSSP123</p>
#12x2" Flat Head #14x2" Flat Head Stainless Steel Screw 	<ul style="list-style-type: none"> Fasten post base plate to 1 5/8" or 2 1/2" post material Fasten 3/8" post base plate to post material Mill finish only <p style="text-align: right;">MFSCDTW122 MFSCDTW142</p>
#12x1 1/2" Pan Head Stainless Steel Screw 	<ul style="list-style-type: none"> Fasten wall plate or wall mount to wood wall Can be ordered painted or mill finish <p style="text-align: right;">MFSCSSP12112</p>
#12x 1" Pan Head Stainless Steel Screw 	<ul style="list-style-type: none"> Fasten post mount plate for XLPR over 2 1/2" post Mill finish only <p style="text-align: right;">MFSCSSP12100</p>
#10x1 1/2" TEK #10x2 1/2" TEK #12X1" TEK Stainless Steel Screw 	<ul style="list-style-type: none"> Fasten inside top rail sleeve to post or stair post Mill finish only <p style="text-align: right;">MFSCSSP10112 MFSCSSP10212 MFSCSSP12100</p>
#10X1 1/2" Pan Head with #8 Head Stainless Steel Screw 	<ul style="list-style-type: none"> Fasten receiver clip to post Fasten receiver channel or post mount plate to top of post Mill finish only <p style="text-align: right;">MFSCSSP101128</p>
#12 x 1" Tek Hex Head Stainless Steel Screw 	<ul style="list-style-type: none"> Secure top sleeves to top rail Secure top rail to post mount plate <p style="text-align: right;">MFSCSSTEKHH12X1</p>
#10x3/4" TEK Stainless Steel Screw 	<ul style="list-style-type: none"> Secure top sleeve post mount to post Fasten wall mount to post Secure bottom wall mount to bottom rail Secure post mount plate to top rail Secure top sleeves to top rail Fasten gate hinges to post <p style="text-align: right;">MFSCSSP1034</p>
#10x3/4" Flat Head With #7 Head UC Cad Plated Screw 	<ul style="list-style-type: none"> Fasten 1 5/8" or 1.72" post caps Mill finish only <p style="text-align: right;">MFSCCDUC10347</p>
#8x1 1/4" Flat Head Cad Plated Screw 	<ul style="list-style-type: none"> Fasten Excell top rail end cap to top rail PUP Cap (Black or White) Mill finish only <p style="text-align: right;">MFSCCW8114</p>
Gate Kit Screw Package 	<ul style="list-style-type: none"> Secure 2x female gate hinges together as a door pin Mill finish only <p style="text-align: right;">MFSCGKSP</p>
3" x 3/8 SS LAG w/ washer 4" x 3/8 SS LAG w/ washer 5" x 3/8 SS LAG w/ washer Stainless Steel 	<ul style="list-style-type: none"> Fasten post to wood deck 5" Usually Meets all Engineering Requirements Mill finish only <p style="text-align: right;">MFSCSSHLAG3W MFSCSSHLAG4W MFSCSSHLAG5W</p>
#14 x 1" Flat Head Screws Stainless Steel 	<ul style="list-style-type: none"> Fasten XLPR plate to PUP post or 2 1/2" HD post Mill finish only <p style="text-align: right;">MFSCSSP14100</p>

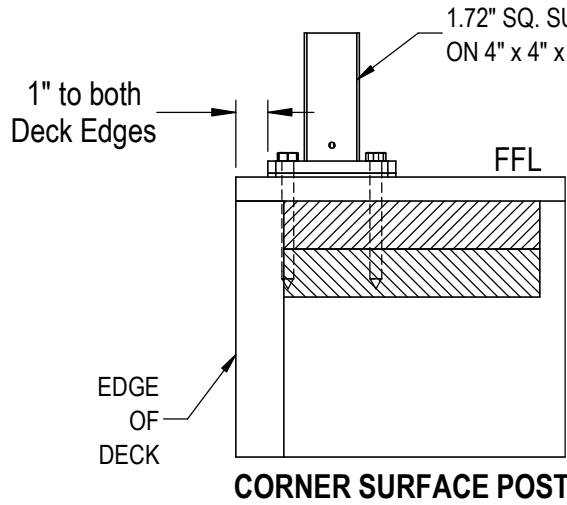

CORNER SURFACE POST

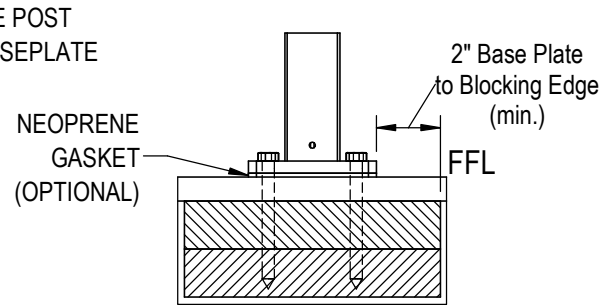

INLINE SURFACE POST

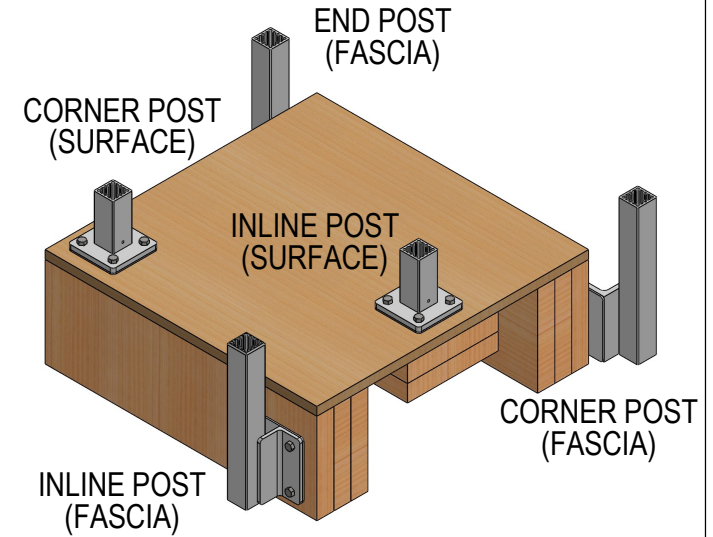

NOTE: Deck Fasteners are subject to Engineering Requirements on a job-by-job basis.

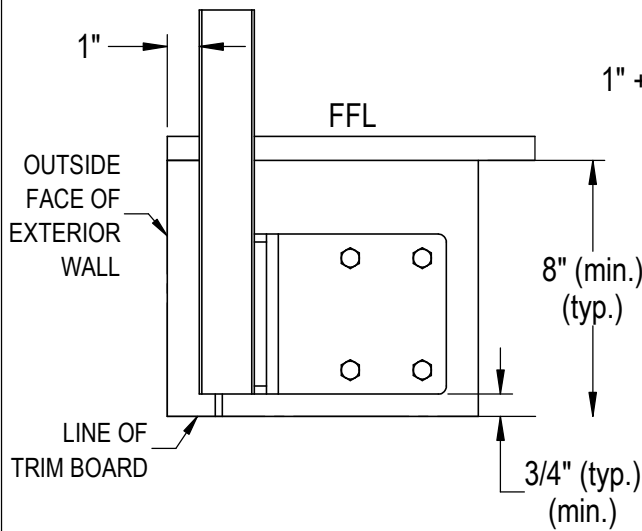

END FASCIA POST

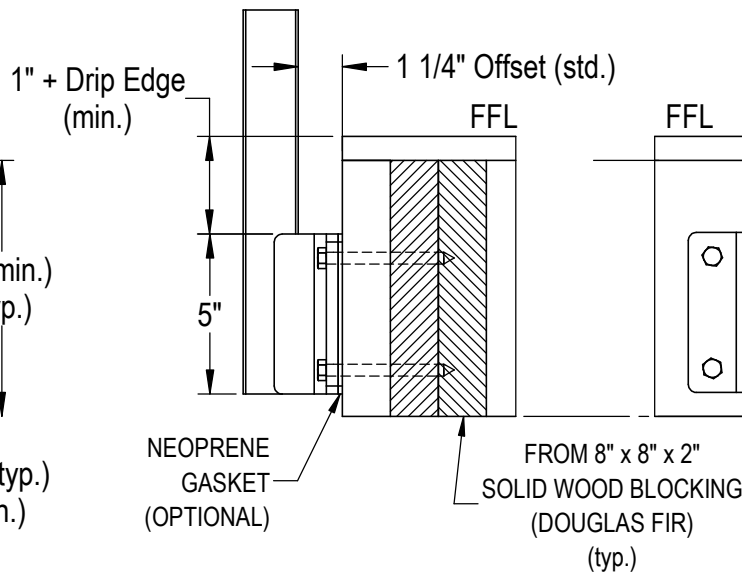

SECTION DETAIL @ FASCIA

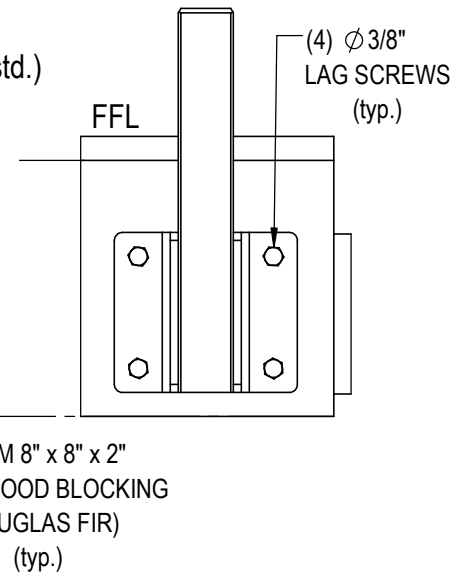

INLINE FASCIA POST

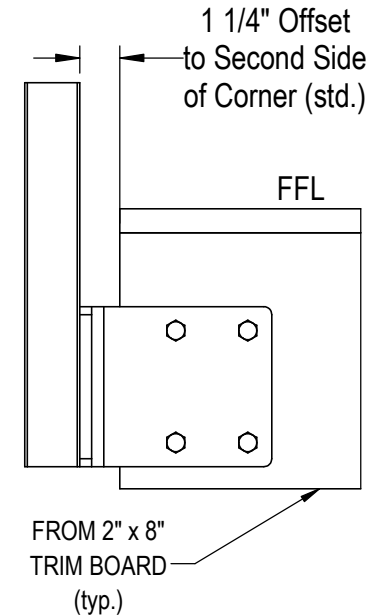

CORNER FASCIA POST



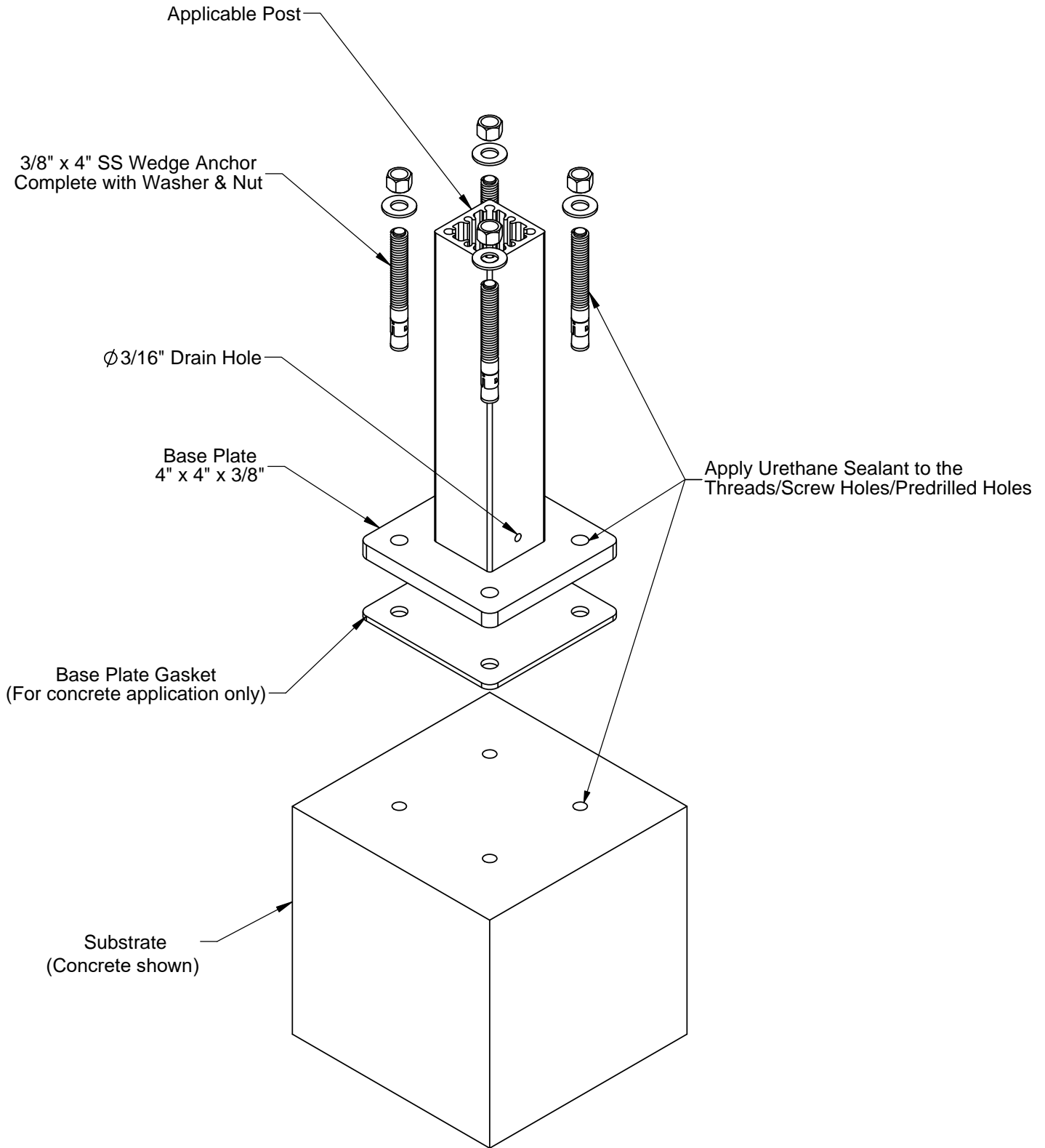

ALL DIMENSIONS ARE SUBJECT TO SITE MEASUREMENTS AND ARE TO BE CONFIRMED BEFORE FABRICATION OF PRODUCT

Authorization Signature	Date of Authorization	Drawing Name	Generic Post Attachment to Wood		
		Customer	Excell Railings		
		Project Name	Product Development		
		Drawn By	Rolly Gatus - rev RDM	Date Created	June 22, 2016
		Revision No.	1	Scale	NTS
				Last Update	April 4, 2024



PLEASE NOTE THAT ALL DIMENSIONS ARE SUBJECT TO SITE MEASUREMENTS AND ARE TO BE CONFIRMED BEFORE FABRICATION OF PRODUCT

 <p>Excell Railing Systems Ltd. #306 - 12886 Anvil Way Surrey, BC Canada V3W 8E7 Phone: 604-501-0151 Fax: 604-501-0155 Toll Free: 1-866-999-7245 www.excellrailing.com</p>	Authorization Signature		Date of Authorization		
	<p>Drawing Name Post Installation Method with Wedge Anchors</p>				
 <p>Durarail Kansas City Warehouse 1722 Iron Street North Kansas City, MO 64116 Toll Free: 1-800-338-3568 Fax: 1-816-421-2924 www.durarail.com</p>	<p>MANUFACTURER OF EXCELL & DURARAIL PRODUCT LINES</p>		<p>Customer Excell / Durarail Railing Systems</p>		
	<p>Project Name Installation Documentation</p>		<p>Drawn By Csaba Bezzegh</p>		
	<p>Revision No.</p>		<p>Scale NTS</p>		<p>Date Created January 4, 2011</p>
	<p>Last Update</p>		<p>Last Update</p>		
	<p>\\EXCELL01\Sales\Drawing Library\Miscellaneous\Assembly Templates\General\Post IM (Wedge Anchors)</p>				

PLEASE NOTE:

Does not work if Nose of Tread (overhang) is $> 1/2"$ (on Stair Angles $> 34^*$). (due to lack of blocking for screws). - See Detail View F below

Does not work if stair angle is $> 37^*$ or $< 31^*$.
 First Cable Hole is $3" \varnothing$ above FFL.
 Holes are $3-1/8" \varnothing$ from Cable-to-Cable
 Mid Post cable holes are drilled on the angle of stairs

Gate Sleeve (SLVXLSQGAT180CUS1) (if Ending at Post)
 OR
 Top Sleeve (SLVXLSQCUS1) (if continuing past post)
 (180° to ST* DN with angle change at post edge - for mounting on 2" post)

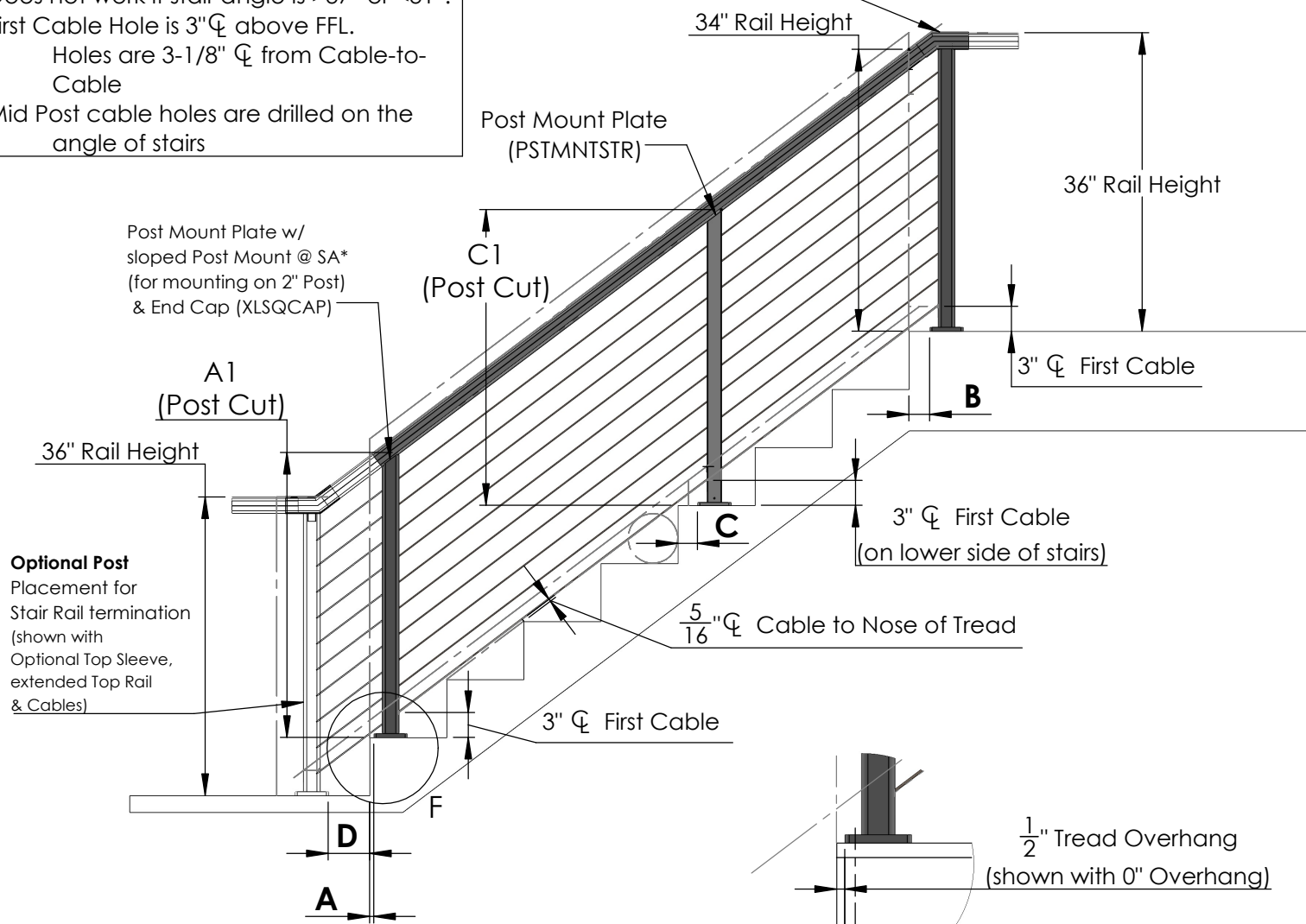

See Sheet "**Table for Generic Cable Stairs**" for layout dimensions by Stair Angle.

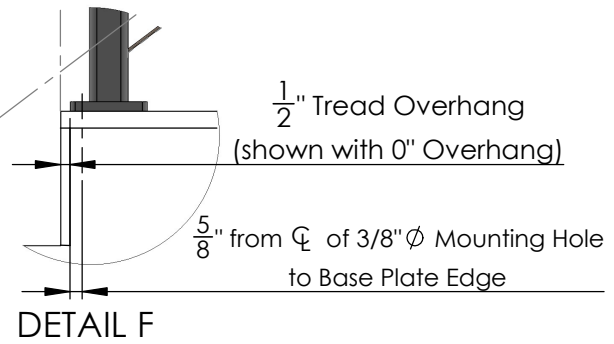

Drawing Name:
Cable Stairs - Generic Layout
31-37deg - Surface Mount R2

Customer:
 Excell Railing System

Project Name:
 Cable Railing
 Generic Stairs
 31* to 37*
 Surface Mount

Dwn By: RDM Chk'd By: --

Date Created: April 17, 2024

Scale: Not To Scale

GENERAL NOTES:

MATERIALS:

- Aluminum alloy and temper:
Posts 6005A-T61
Rails 6063-T5
Baseplate 6005A-T61
- Design Specifications and Standards for Aluminum Structures Aluminum Association
- Screws for railing system assembly as per manufacturer's specification

POWDER COATING SPECIFICATION:

- Finished powder coat color is **TBD**
- Powder coat meet AAMA-2604-02 Voluntary Specifications.
- Performance Requirements and Test Procedures for Pigmented Organic Coatings on Aluminum Extrusions and Pickets.

OTHERS:

- Rail assembly to meet all specification requirements as stated in attached
- Contractor to field verify all dimensions and quantities prior to fabrication

ENGINEERING STAMP & DATE		
2	RM	Table moved to own sheet - 4/30/2024
1	RM	Table Adds & Added Notes - 4/19/2024
No.	BY	Revision

ALL DIMENSIONS ARE SUBJECT TO SITE MEASUREMENTS AND ARE TO BE CONFIRMED BEFORE FABRICATION OF PRODUCT



#306 - 12886 Anvil Way Surrey, BC V3W 8E7
 Phone: 604-501-0151 Fax: 604-501-0155
 Toll Free: 1-866-999-7245 www.excellrailing.com

Drawing Name:
Table for Generic Cable Stairs

Customer:
 Excell Railing System

Project Name:
 Cable Railing
 Generic Stairs
 31* to 37*
 Surface Mount

Dwn By: RDM Chk'd By: --

Date Created: April 30, 2024

Scale: Not To Scale

GENERAL NOTES:

- MATERIALS:**
- Aluminum alloy and temper:
Posts 6005A-T61
Rails 6063-T5
Baseplate 6005A-T61
 - Design Specifications and Standards for Aluminum Structures Aluminum Association
 - Screws for railing system assembly as per manufacturer's specification

- POWDER COATING SPECIFICATION:**
- Finished powder coat color is **TBD**
 - Powder coat meet AAMA-2604-02 Voluntary Specifications. Performance Requirements and Test Procedures for Pigmented Organic Coatings on Aluminum Extrusions and Pickets.

- OTHERS:**
- Rail assembly to meet all specification requirements as stated in attached
 - Contractor to field verify all dimensions and quantities prior to fabrication

ENGINEERING STAMP & DATE

-	-	Per E-Mail received (date)
No.	BY	Revision

Post Placement by Stair Angle

Stair Angle	(A) Bottom Post Tread Nose-to-Base Plate Edge / ($\frac{1}{4}$ Mounting Hole)	(A1) Bottom Post Cut Long side Cut Length (Cut on Stair Angle)	(B) Top Post Tread Nose-to-Base Plate Edge	(C) Mid Post Tread Nose-to-Base Plate Edge	(C1) Mid Post Cut Long Side Cut Length (Cut on Stair Angle)	(D) Optional Post Tread Nose-to-Base Plate Edge
31*	1" (1-9/16")	34"	3"	2-7/8"	35"	4-1/2"
32*	15/16" (1-1/2")	34"	2-15/16"	2-13/16"	35-1/16"	4-9/16"
33*	13/16" (1-3/8")	34"	2-13/16"	2-11/16"	35-1/16"	4-11/16"
34*	3/4" (1-5/16")	34"	2-3/4"	2-5/8"	35-1/8"	4-3/4"
35*	11/16" (1-1/4")	34"	2-11/16"	2-9/16"	35-1/8"	4-13/16"
36*	9/16" (1-1/8")	34"	2-9/16"	2-7/16"	35-3/16"	4-15/16"
37*	1/2" (1-1/16")	34"	2-1/2"	2-3/8"	35-3/16"	5"

ALL DIMENSIONS ARE SUBJECT TO SITE MEASUREMENTS AND ARE TO BE CONFIRMED BEFORE FABRICATION OF PRODUCT